



---

WATER ELECTROLYZER

# INSTALLATION MANUAL

**ROX-10WB-E**  
**ROX-20TB-E**  
**JIX-40T\_**

FOR QUALIFIED INSTALLER ONLY

L288AV111 (120307)

## IMPORTANT

Only qualified service technicians should attempt to install, service or maintain this product. No installation, service or maintenance should be undertaken until the technician has thoroughly read this Installation Manual. Likewise, the owner/manager should not proceed to operate the product until the installer has instructed them on its proper operation.

HOSHIZAKI provides this manual primarily to assist qualified service technicians in the installation, maintenance and service of the product.

Should the reader have any questions or concerns which have not been satisfactorily addressed, please call or write to the HOSHIZAKI International Sales & Marketing Department.

HOSHIZAKI ELECTRIC CO., LTD.  
3-16 Minamiyakata, Sakae  
Toyoake, Aichi 470-1194 Japan

Attn: International Sales & Marketing Department

Phone: +81 562 97 2119

Fax: +81 562 97 1675

Note: To expedite assistance, all correspondence/communication MUST include the following information:

- \* Model Number
- \* Serial Number
- \* Complete and detailed explanation of the problem

\* Please review this manual. It should be read carefully before the water electrolyzer is installed and operated. Only qualified service technicians should install, service and maintain the water electrolyzer. This manual should be made available to the technician prior to installation, maintenance or service.

\* Keep this manual with the water electrolyzer for later reference.

## CONTENTS

PAGE

I.	INSTALLATION OF ROX-10WB-E-----	1
	1. UNPACKING-----	1
	2. CHECKS BEFORE INSTALLATION-----	2
	3. INSTALLATION -----	2
	[a] REQUIRED TOOLS -----	3
	[b] SET UP -----	3
	4. ELECTRICAL CONNECTIONS-----	5
	5. WATER SUPPLY AND DRAIN CONNECTIONS -----	5
	[a] WATER SUPPLY CONNECTIONS -----	6
	[b] REMOTE PIPE CONNECTIONS -----	7
	[c] DRAIN CONNECTIONS-----	8
	6. VENTILATION-----	8
	7. TRIAL RUN-----	9
	[a] WATER LEAKS-----	9
	[b] AFTER TRIAL RUN-----	9
	8. ADJUSTMENT -----	10
	9. BEFORE USING ELECTROLYZED WATER-----	11
II.	INSTALLATION OF ROX-20TB-E AND JIX-40T_-----	12
	1. CHECKS BEFORE INSTALLATION-----	12
	2. LOCATION -----	12
	3. ELECTRICAL CONNECTION-----	13
	4. INSTALLATION OF WATER SOFTENER (SOLD SEPARATELY) AND WATER FILTER (SOLD SEPARATELY)-----	14
	[a] CHECKS BEFORE INSTALLATION-----	14
	[b] LOCATION-----	14
	[c] SET UP -----	14
	[d] ELECTRICAL CONNECTION-----	14
	[e] WATER SUPPLY AND PLUMBING CONNECTIONS-----	15
	5. INSTALLATION OF REMOTE CONTROLLER (ACCESSORY)-----	15
	[a] CHECKS BEFORE INSTALLATION-----	15
	[b] LOCATION-----	15
	[c] SET UP -----	16
	[d] ELECTRICAL CONNECTION-----	18
	6. INSTALLATION OF WATER TANK FLOAT SWITCHES (OPTION) AND WATER TANK (SOLD SEPARATELY)-----	18

[a] CHECKS BEFORE INSTALLATION-----	18
[b] LOCATION-----	19
[c] SET UP -----	19
[d] ELECTRICAL CONNECTION-----	20
7. INSTALLATION OF OUTLET VALVES (OPTION) -----	21
[a] CHECKS BEFORE INSTALLATION-----	21
[b] LOCATION-----	21
[c] SET UP -----	22
8. WATER SUPPLY AND PLUMBING CONNECTIONS -----	23
[a] UNIT WITH REMOTE CONTROLLER, WATER SOFTENER & WATER FILTER -----	23
[b] UNIT WITH WATER TANK, WATER SOFTENER & WATER FILTER -----	25
9. ADJUSTMENT -----	30
[a] OPERATION MODE-----	30
[b] CURRENT, VOLTAGE, PORTION CONTROL DISPENSING TIME, HANDWASHING TIME (ROX-20TB-E)-----	31
[c] CURRENT, VOLTAGE, PORTION CONTROL DISPENSING TIME (JIX-40T_)-----	32
[d] FLOW RATE (JIX-40T_)-----	33
10. FINAL CHECK LIST -----	34
11. WATER TANK FLOAT SWITCHES (OPTION)-----	35
12. OUTLET VALVES (OPTION)-----	35

## I. INSTALLATION OF ROX-10WB-E

### WARNING

1. To prevent a possible water leak, electric shock or fire, the installation must be carried out by qualified personnel.
2. Ensure adequate ventilation. Hydrogen or chlorine gas generated from electrolyzed water may cause health problems.
3. Electrolyzed water is not intended for drinking. Any usage other than handwashing or utensil washing may lead to health problems.
4. This unit requires a ground that meets the national and local electrical code requirements. Do not connect the ground wire to a gas or water main, lightning rod or telephone ground wire. Improper grounding may cause electric shock.
5. This unit is not intended for outdoor use or installation under eaves. Exposure to rainwater may cause an electric leak or shock.
6. Do not install the unit where exposed to humidity or water splashes. Degradation of insulation may cause an electric leak or shock.

### CAUTION

1. To maintain the optimum performance, this unit requires daily maintenance and periodic inspection. The operation and maintenance of the unit should be limited to an exclusive operator. This is also to prevent possible misuse and resulting failure.
2. Install the unit horizontally on a solid vertical wall to avoid the risk of water leaks or injury caused by overturn or fall.
3. This unit is not suitable for installation in an area where dripping of water or salt is not allowed. Water may drip onto the floor when salt water is added to the Salt Water Tank.
4. Avoid direct sunlight and ensure adequate ventilation. Ultraviolet rays will deteriorate acid (sanitizing) water.

## 1. UNPACKING

### CAUTION

1. To prevent injury, do not lift or maneuver the carton by using the shipping bands.
2. Carry the carton by holding the bottom. Careless handling may cause injury.

- 1) Remove the shipping tape from the carton.
  - 2) Open the top of the carton, and remove the covered unit.
  - 3) Take out the package of accessories from the carton.
  - 4) Remove the plastic cover from the unit, the vinyl tape securing the Power Cord, Salt Water Hose and Front Cover, and the plastic cover from the Water Inlet, Alkaline (Cleaning) Water Outlet and Acid (Sanitizing) Water Outlet.
- \* Do not remove the labels. If any of them comes off, purchase it from an authorized Hoshizaki service company, and attach it in a correct position.

## 2. CHECKS BEFORE INSTALLATION

- 1) Check the exterior and interior parts for damage or defects.
  - 2) Check for missing or damaged accessories according to "I. 3. ACCESSORIES" in the instruction manual.
- \* If any part is found missing or damaged, contact an authorized Hoshizaki service company.
- \* The instruction manual must be handed over to the user.

## 3. INSTALLATION

### WARNING

1. To prevent a possible water leak, electric shock or fire, the installation must be carried out by qualified personnel according to this Installation Manual. After installation is complete, make a trial run to ensure proper operation. The user must be instructed on how to use and maintain the unit in accordance with the instruction manual.
2. This unit is not intended for outdoor use. Exposure to rainwater may cause an electric leak or shock.
3. Do not install the unit where exposed to humidity or water splashes. Degradation of insulation may cause an electric leak or shock.
4. Do not use heat producing equipment in contact with or near the unit. The plastic parts may melt.

### CAUTION

1. By using the Anchor Bolts (accessory), install the unit horizontally on a solid

vertical wall to avoid the risk of water leaks or injury caused by overturn or fall.

2. Do not install the unit where subfreezing temperatures are expected. If the ambient temperature can fall below zero, drain the unit to prevent water leaks caused by damage to the piping.
3. Do not put heavy things or water containing vessels on the unit. They could fall off and cause injury, or spilt water may degrade the electrical insulation and increase the risk of electric leaks.
4. This unit is not suitable for installation in an area where dripping is not allowed. Condensate water may drip onto the floor in a humid condition.
5. Do not place any precision instruments between the unit and ventilator. Chlorine gas may cause corrosion or failure.
6. To prevent an electric leak or shock, do not install the unit on a wall exposed to water or steam.

\* Normal operating ambient temperature should be within 5°C to 30°C (40°F to 95°F), and water temperature within 5°C to 35°C (40°F to 85°F). Operation outside of this temperature range may result in inadequate performance or improper operation.

## [a] REQUIRED TOOLS

Phillips screwdrivers (large and small)  
Precision screwdrivers (Phillips and flat blade)  
Sealing tape  
Pipe wrench pliers  
Monkey wrench  
Drill (for wall)  
Drill bits [6 mm (1/4") DIA]  
Voltage/current tester  
pH tester  
Chlorine test paper or thiosulfate titration kit

## [b] SET UP

### (1) Horizontal Adjustment

Level the unit in both the left-to-right and front-to-rear directions.

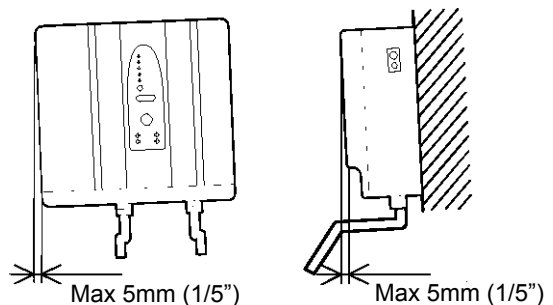

**(2) Spacing**

Allow the following clearance around the unit for proper operation and ease of maintenance and/or service.

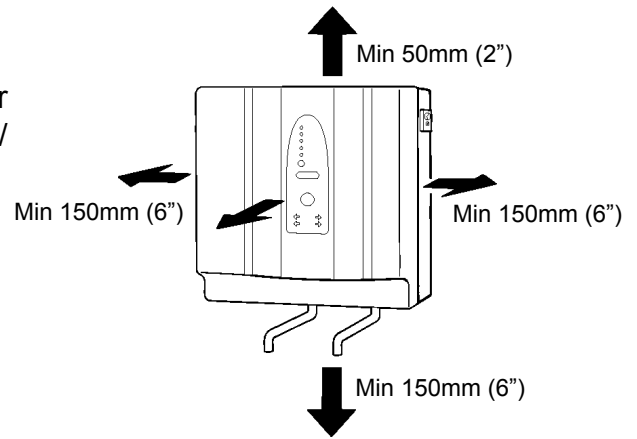

**(3) Wall Mounting**

1) Drive the Anchor Bolt [MiL-8] (accessory) into the wall, and attach the Screw Collar (accessory) and Wood Screw (accessory). The hole must be 6 mm (1/4") in diameter and at least 28 mm (1") deep.

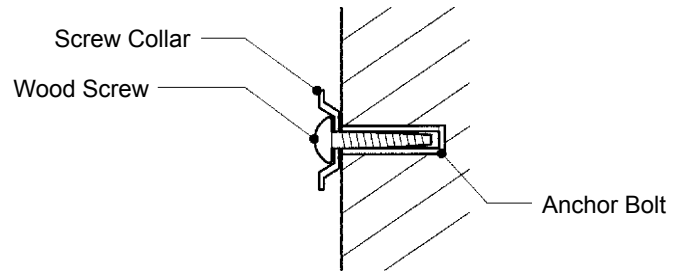

The mounting pitch must be as shown below.

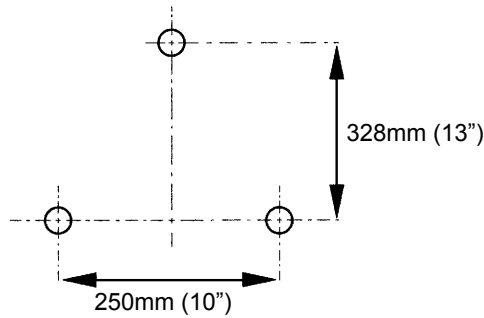

2) Set up the unit on the Screw Collar, and use the Wood Screws (accessory) to secure the unit on the wall [with a 250 mm (10 inch) pitch].

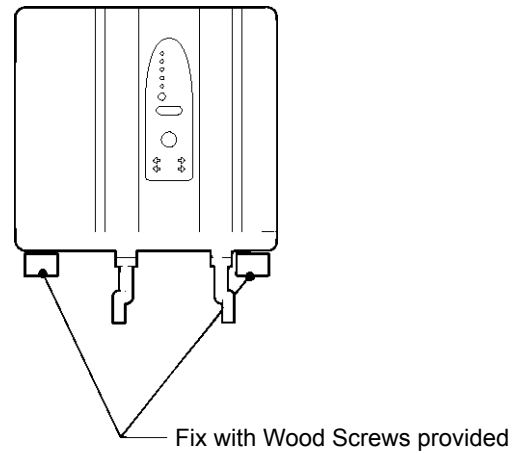

## 4. ELECTRICAL CONNECTIONS

### WARNING

1. This water electrolyzer must have a separate power supply or receptacle of proper capacity. Branching off the Power Cord, using an extension cord or sharing a single power supply with other appliances may result in an electric shock, heat generation or fire.
2. The water electrolyzer requires a ground that meets the national and local electrical code requirements. To prevent possible electrical shock to individuals or extensive damage to equipment, plug the electrolyzer only into a properly grounded electrical outlet.

### CAUTION

The maximum allowable voltage variation should not exceed  $\pm 10$  percent of the rated voltage. Operation of the unit outside of this range may cause damage to the unit or reduction of the performance.

\* Usually an electrical permit and services of a licensed electrician are required.

## 5. WATER SUPPLY AND DRAIN CONNECTIONS

### CAUTION

1. Install the Pressure Regulating Valve provided to maintain the water supply pressure within 0.1 - 0.75 MPa (22 - 109 PSIG). Operation without the Valve or any pressure exceeding this limit may cause failure, inadequate water quality or water leaks, resulting in damage to surrounding properties.
2. Install a Water Softener and Cartridge Filter to prevent clogged pipes, reduction in electrolytic capacity, and electrolytic cell failure.

\* Always locate the Salt Water Tank below the end of the Water Outlets, or the Tank will leak salt water by siphonage.

\* Use of potable water containing a large amount of carbon dioxide can cause reduction in electrolyzed capacity and production of alkaline (cleaning) and acid (sanitizing) water with improper pH levels. In such case, contact an authorized Hoshizaki service company.

\* Water left inside the Water Softener may be stained light yellow when discharged, which is not harmful to the health. In such case, open the gauge cock of the Water Softener to completely drain out stained water.

## Example

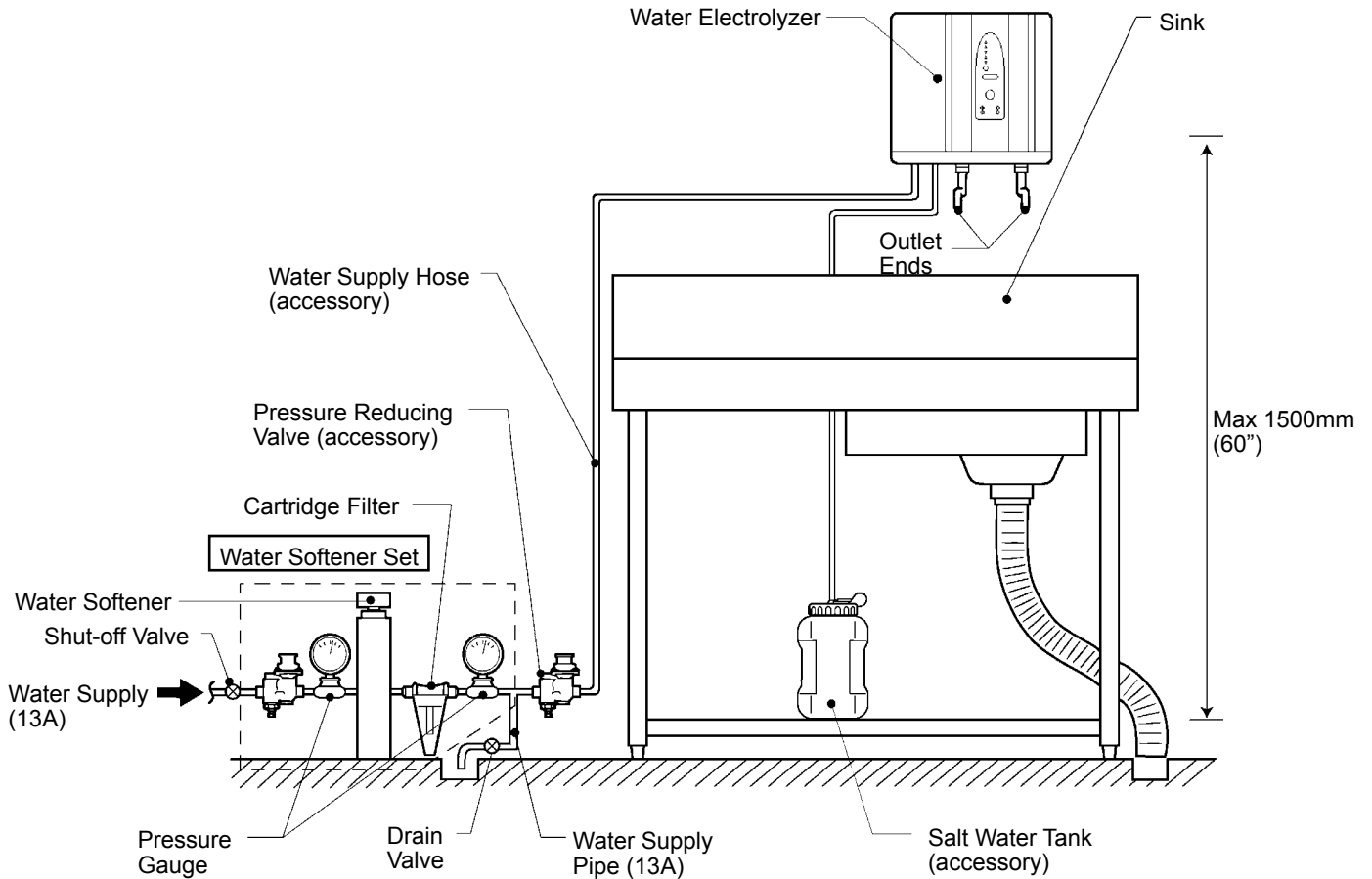

### [a] WATER SUPPLY CONNECTIONS

#### CAUTION

Use potable water only. Use of non-potable water may cause corrosion, clogged pipes, or poor performance.

- \* The water supply pipe must be a flexible tube, PVC pipe, PVC lined steel pipe or equivalent, which is recognized by the local waterworks bureau.
  - \* Before making connections, clean the pipes thoroughly to remove any chips, cutting oil and foreign matter attached inside. They may clog the Pressure Reducing Valve (accessory) or Water Valve inside the unit.
- 1) Install the Water Softener (option) in the primary side (water inlet) of the water supply line.
  - 2) Install the Cartridge Filter (Water Softener accessory) between the Water Softener and unit.

3) Install the Pressure Gauges in the locations as shown below.

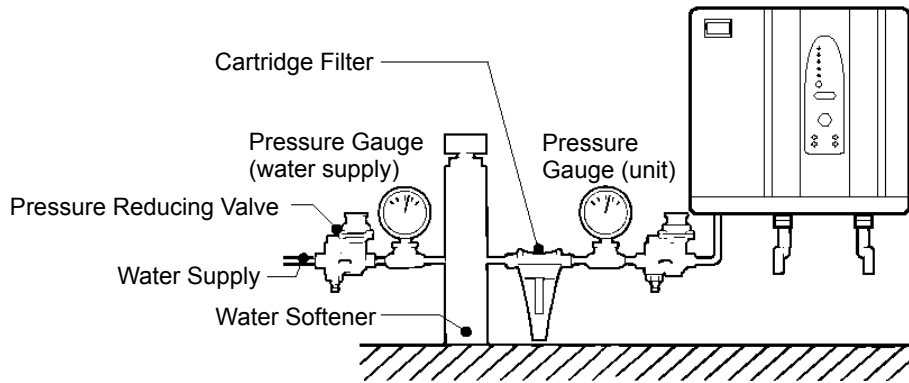

\* The Pressure Reducing Valve (accessory) must be installed in the proper direction between the Pressure Gauge (unit side) and the water inlet on the unit.

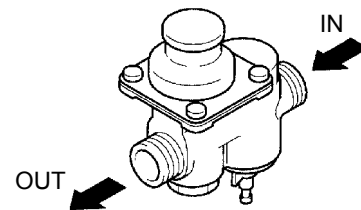

\* To prevent water leaks, attach the Gaskets (black) properly between the Water Supply Hose (accessory) and water inlet on the unit and between the Hose and Pressure Reducing Valve (accessory), and securely tighten the joints.

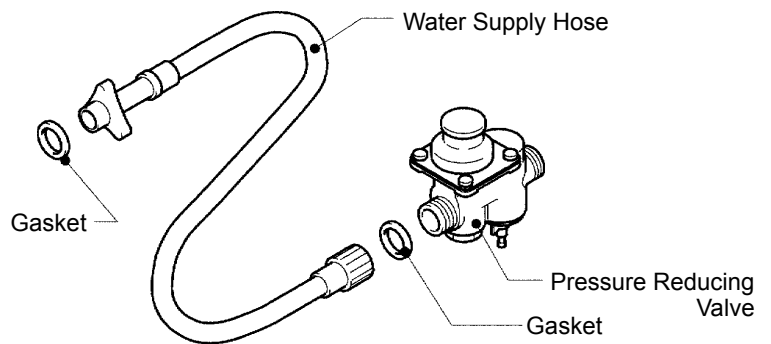

\* The Branch Outlet (option) must be installed for branching the main water line to the unit.

\* The Water Supply Line Shut-off Valve (option) must be installed between the Branch Outlet and water inlet on the unit.

\* Before installing the Branch Outlet, check for foreign matter and remove it if any.

\* Use a sealant, sealing tape or gasket to make watertight joints. Do not use a sealant that may clog pipes or give odor to water.

**[b] REMOTE PIPE CONNECTIONS**

**CAUTION**

The pipes for dispensing electrolyzed water must be the Remote Pipes (accessory) or PVC hoses. Other materials may cause corrosion resulting in water leaks.

- \* The pipe ends must be left open to prevent failure. Do not install shut-off valves at the ends or on the way to the ends, nor immerse the pipe ends in water.
- \* To ensure adequate water flow, do not stand up the pipes.
- \* Check that the O-Rings (accessory) are provided inside, and tightly secure the Remote Pipes (accessory) to the bottom of the unit. Loose connections may result in water leaks.

## **[c] DRAIN CONNECTIONS**

- \* Make drain connections, if the unit needs to be drained.
- \* Drain connections are required in cold regions where water may freeze inside the unit.

### **CAUTION**

1. The drain pipe must be a PVC pipe or acid- and alkali-resistant hose. Other materials may cause corrosion resulting in water leaks.
2. To prevent corrosion of the unit and surrounding equipment, do not drain directly onto the floor.
3. To avoid corrosion of the drain pipe and water leaks, always neutralize electrolyzed water before draining it out.

## **6. VENTILATION**

### **WARNING**

Ensure adequate ventilation. Hydrogen or chlorine gas generated from electrolyzed water may cause health problems.

- \* Ventilate the installation site at an airflow of 450 m<sup>3</sup>/h (270 ft<sup>3</sup>/min) or more to meet the environmental standards requiring a chlorine concentration of 0.1 ppm or less. Use a ventilation fan, if necessary, of at least 15 cm (1/2 foot) in diameter [standard airflow 450 m<sup>3</sup>/h (270 ft<sup>3</sup>/min)] and made of a non-corrosive or corrosion-resistant material.
- \* Do not locate the exhaust duct near a gas pipe or corrosive materials.
- \* Locate the ventilation fan as close as possible to the point of use of electrolyzed water.
- \* Do not exhaust in the presence of fire.

## 7. TRIAL RUN

### WARNING

1. Do not splash water directly onto the unit. It may cause short circuits, electric shocks, corrosion or failure.
2. To prevent an electric shock, do not touch the Attachment Plug, Power Switch, or other electrical parts with damp hands.
3. This unit should be disassembled or repaired only by qualified service personnel to prevent the risk of injuries, electric shocks or fires.
4. Do not make any alterations on the unit. It could cause water leaks, electric shock or fire.

Check for proper operation in accordance with “III. 1. START UP” in the instruction manual.

- \* Check the dispensed water according to “IV. MAINTENANCE” in the instruction manual.
- \* See “I. 2. CONSTRUCTION” in the instruction manual for how to indicate the electrolytic cell running time, current and voltage.
- \* If the pH value or available chlorine concentration is found outside the specified range, adjust it in accordance with “8. ADJUSTMENT”. If it still stays outside the range, contact an authorized Hoshizaki service company.
- \* If a problem is found with operation of the unit, contact an authorized Hoshizaki service company.
- \* In the initial setting of the Water Softener, regeneration is required to flush the ion exchange resin. Electrolyzed water may be colored.

#### [a] WATER LEAKS

- 1) While the unit is running, visually check every part for water leaks.
  - 2) Check the water supply and drain circuits for water leaks.
- \* If a leak is found, repair it in accordance with “5. WATER SUPPLY AND DRAIN CONNECTIONS”. If the leak still exists, contact an authorized Hoshizaki service company.

#### [b] AFTER TRIAL RUN

- 1) Turn OFF the Power Switch.

- 2) Close the Water Supply Line Shut-off Valve.
- 3) Open the Drain Valve to drain the water supply line (see “5. WATER SUPPLY AND DRAIN CONNECTIONS”).
- 4) Clean the Strainer of the Pressure Reducing Valve (accessory) to remove dust or dirt inside. Remove the Cap by turning it counterclockwise.

## 8. ADJUSTMENT

Some changes in pH value and available chlorine concentration will be available by changing the electrolytic current (factory adjusted to 10A). This change should be made by qualified service personnel only when the pH value or available chlorine concentration is outside the specified range.

The dispensing amount in the portion control dispensing mode is also adjustable by changing the portion control dispensing time.

\* When adjustment is required, contact an authorized Hoshizaki service company.

\* If the Water Softener needs adjustment, contact its manufacturer or an authorized Hoshizaki service company (see the instruction manual provided with the Water Softener).

- 1) Turn on the Power Switch.
- 2) For current adjustment only, press the Flow Rate Button to illuminate the selected Flow Rate Lamp (LO, MID or HI).
- 3) Hold down the Set Button.
- 4) Check that the Display Window is showing "Nor". "Nor" indicates that the unit is currently in the Normal Mode.
- 5) Press the Display Select Button once while holding down the Set Button.
- 6) Check that the Display Window is showing "AdJ". "AdJ" indicates that the unit is currently in the Adjust Mode.
- 7) Release the Set Button.
- 8) Check that the Display Window is showing "A1". "A1" indicates that the unit is in Stage 1 of the Adjust Mode. Press the Display Select Button to select the appropriate stage.
  - A1: Current
  - A5: Portion control dispensing time
- 9) If the Display Select Button is pushed more than necessary and the Display Window shows a code other than desired, continue to push the Display Select Button until the proper code reappears.

- 10) Press the \* Button once.
- 11) The Display Window will flash the current setting. The factory settings are as follows:  
Current: "10.0" (10A)  
Portion control dispensing time: "1" (1 minute)
- 12) Press the Display Select Button (Up) or \* Button (Down) until the desired value is displayed. The Display Window continues to flash.  
To raise the pH and available chlorine concentration, increase the current. To lower the pH and concentration, decrease the current.
- 13) When the desired value appears in the Display Window, press the Set Button once.
- 14) The value displayed in the Display Window will stop flashing. Check that the Adjust Mode Code appears in the Display Window.
- 15) Press the Display Select Button once holding down the Set Button.
- 16) Check that "CHE" is displayed in the Display Window. "CHE" indicates that the unit is in the Check Mode.
- 17) Press the Display Select Button one more time holding down the Set Button.
- 18) Check that "Nor" is displayed in the Display Window.
- 19) Release the Set Button.
- 20) This is the end of setting. Check for proper operation.

## II. INSTALLATION OF ROX-20TB-E AND JIX-40T\_

### 1. CHECKS BEFORE INSTALLATION

#### IMPORTANT

1. Remove shipping carton and tape(s). If packaging material is left in the water electrolyzer, it will not work properly.
2. Use potable water. If water other than potable water is used, it may clog pipes, cause poor performance, etc.
3. Purchase the Water Tank Float Switch (Option).
4. Install a water softener and water filter (sold separately) on the water electrolyzer to improve machine performance and prevent electrolytic cell damage, etc.

- 1) Be sure not to damage the panels when installing the water electrolyzer.
- 2) Remove the package containing the accessories.
- 3) See the Nameplate on the Rear Panel and check that the voltage supplied corresponds with the voltage specified on the Nameplate.

### 2. LOCATION

#### WARNING

1. This water electrolyzer is not intended for outdoor use. Normal operating ambient temperature should be within 5°C to 35°C (40°F to 95°F); Normal operating water temperature should be within 5°C to +0°C (40°F to 85°F). Operation of the water electrolyzer for extended periods outside of these normal temperature ranges may affect performance.
2. Do not install the unit where exposed to humidity or splashing water. Reduction in insulation property may cause an electric leak or shock. Locations should be at least 6" above the floor to avoid splashing water during kitchen cleaning operations.
3. Install adequate ventilating system. Hydrogen gas or chlorine gas may cause health problems.

## CAUTION

1. To prevent damage to the unit, do not move the unit with the Door open.
2. The unit should not be submerged in water or become wet.
3. Use glass, plastic or stainless steel containers for electrolyzed water. Acid (sanitizing) water may corrode metal.

For best operating results:

- \* The water electrolyzer should not be located next to ovens, grills or other high heat producing equipment.
- \* Location should provide a firm and level foundation for the equipment.
- \* Allow 15 cm (6") clearance at rear, sides and top for proper performance and ease of maintenance and/or service.
- \* Install the unit in a well-ventilated area. Use fans with diameter over 15 cm (6 inches) [standard air flow rate: 450 m<sup>3</sup>/h (270 ft<sup>3</sup>/min)] if necessary.

### 3. ELECTRICAL CONNECTION

## WARNING

1. This water electrolyzer must have a separate power supply or receptacle of proper capacity. Branching off the Power Cord, using an extension cord or sharing a single power supply with other appliances may result in an electric shock, heat generation or fire.
2. The water electrolyzer requires a ground that meets the national and local electrical code requirements. To prevent possible electrical shock to individuals or extensive damage to equipment, plug the electrolyzer only into a properly grounded electrical outlet.

## CAUTION

The maximum allowable voltage variation should not exceed  $\pm 10$  percent of the rated voltage. Operation of the unit outside of this range may cause damage to the unit or reduction of the performance.

- \* Usually an electrical permit and services of a licensed electrician are required.

## **4. INSTALLATION OF WATER SOFTENER (SOLD SEPARATELY) AND WATER FILTER (SOLD SEPARATELY)**

### **[a] CHECKS BEFORE INSTALLATION**

- 1) Unpack and remove shipping carton, tape(s) and other packaging material(s).
- 2) Check that all the necessary accessories are included.
- 3) Follow the Instruction Manual for the Water Softener and the Water Filter.

### **[b] LOCATION**

- \* Install the Water Softener and Water Filter under the same ambient temperature and water temperature conditions as the water electrolyzer.
- \* Follow the Instruction Manual for the Water Softener and the Water Filter.

### **[c] SET UP**

- 1) Install the valves and pipes following the Instruction Manual for the Water Softener and the Water Filter.
- 2) Install a water pressure gauge on the pipe of the primary side of the Water Softener and secondary side of the Water Filter.

### **[d] ELECTRICAL CONNECTION**

#### **WARNING**

1. This softener must have a separate power supply or receptacle of proper capacity. Branching off the Power Cord, using an extension cord or sharing a single power supply with other appliances may result in an electric shock, heat generation or fire.
2. The water softener requires a ground that meets the national and local electrical code requirements. To prevent possible electrical shock to individuals or extensive damage to equipment, plug the water softener only into a properly grounded electrical outlet.

#### **CAUTION**

The maximum allowable voltage variation should not exceed  $\pm 10$  percent of the rated voltage. Operation of the unit outside of this range may cause damage to the unit or reduction of the performance.

\* Usually an electrical permit and services of a licensed electrician are required.

## **[e] WATER SUPPLY AND PLUMBING CONNECTIONS**

### **CAUTION**

Do not run the Water Softener and the Water Filter until the proper water pressure is reached.

- \* For piping of the Water Softener and Water Filter, follow the Instruction Manual for the Water Softener and the Water Filter.
- \* Adjust water pressure so that discharge pressure after pipes are connected will be within 0.15 - 0.78MPa (22 - 115PSIG). Also adjust water supply pressure so that it will be within the specified value in the specifications for the Water Softener and the Water Filter.
- \* For air gap between the drain pipe ends or hose ends and a sink or floor drain, follow the Instruction Manual for the Water Softener.
- \* Be sure to flush out a new water softener thoroughly to a sink or drain before connecting it to the water electrolyzer.
- \* A plumbing permit and services of a licensed plumber may be required in some areas.
- \* General piping example for the Water Softener and Water Filter

## **5. INSTALLATION OF REMOTE CONTROLLER (ACCESSORY)**

**Please note that the instructions and illustrations below are based on ROX-20TB-E and that only one water outlet is available for JIX-40T\_.**

### **[a] CHECKS BEFORE INSTALLATION**

- 1) Unpack and remove shipping carton, tape(s) and other packaging material(s).
- 2) Check that all the necessary accessories are included.
- 3) Check that the Remote Controller and water electrolyzer are installed so that the cables and connection hoses of the Remote Controller can reach the water electrolyzer.
- 4) Check if there is any serious damage, broken cable, etc.

## [b] LOCATION

### WARNING

1. This remote controller is not intended for outdoor use. Normal operating ambient temperature should be within 5°C to 35°C (40°F to 95°F); Normal operating water temperature should be within 5°C to 30°C (40°F to 85°F). Operation of the remote controller for extended periods outside of these normal temperature ranges may affect performance.
2. Do not install the remote controller where exposed to humidity or splashing water. Reduction in insulation property may cause an electric leak or shock.
3. Install an adequate ventilating system. Hydrogen gas or chlorine gas may cause health problems.

### CAUTION

1. Avoid a site where dripping is not allowed. Condensation may form on the exterior in high humidity and could drip onto the floor.
2. Use glass, plastic or stainless steel containers for electrolyzed water. Acid (sanitizing) water may corrode metal.

For best operating results:

- \* The Remote Controller should not be located next to ovens, grills or other high heat producing equipment.
- \* Location should provide a firm and level foundation for the equipment.
- \* Install the unit in a well-ventilated area. Use fans with diameter over 15 cm (6 inches) [standard air flow rate: 450 m<sup>3</sup>/h (270 ft<sup>3</sup>/min)] if necessary.

## [c] SET UP

### CAUTION

Use the Accessory Braided Hoses, Connectors and Gaskets for electrolyzed water piping. Other materials may cause corrosion and water leakage.

- 1) Attach the PVC Braided Hose to the Connector with the Clamp.

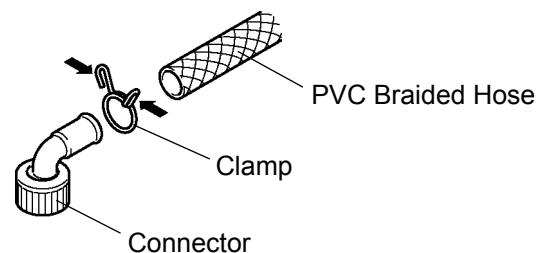

2) Attach the Connectors to the water electrolyzer with the Gaskets between the Connectors and the water electrolyzer. Make sure to check the connection locations for the Acid (Sanitizing) and Alkaline (Cleaning) Water Hoses.

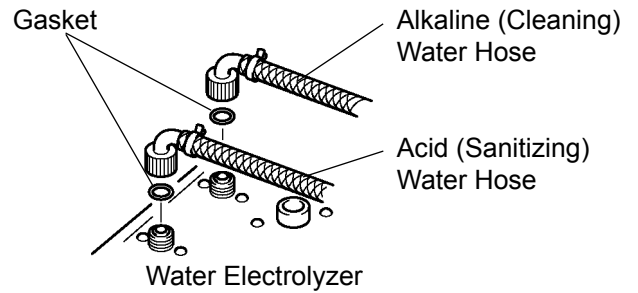

3) Drive M6 anchor bolts into the wall or attach a sheet metal part to the wall to attach the Bracket. The space between bracket holes is 7" and there are two 8mm holes.

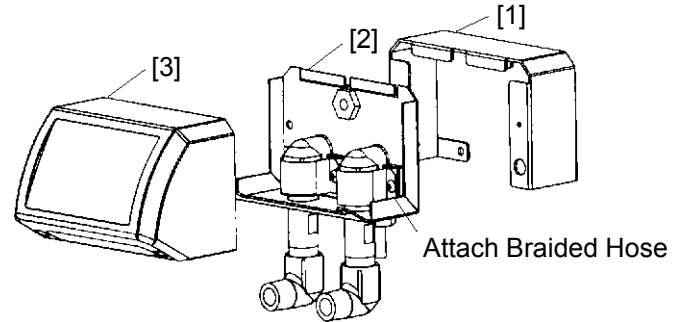

4) Attach the PVC Braided Hoses in step 1) to the part [2] in the illustration. Secure the Remote Controller to the Bracket with M4 x 8 Tapping Screws (Accessory) in the order illustrated.

5) After installing the Remote Controller on the wall, attach the Electrolyzed Water Pipes to the Remote Controller in the order illustrated. Make sure that there are Gaskets on the end of the Pipes.

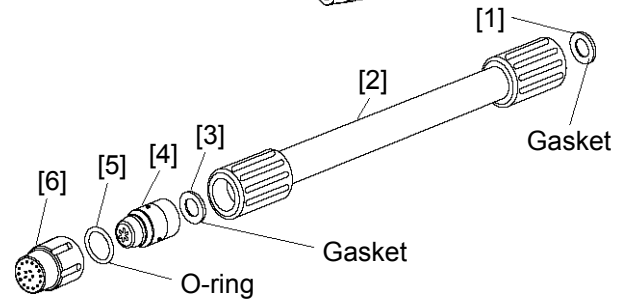

Note: The vertical height of the hoses for electrolyzed water should be a maximum of 80" and the total piping length should be within the range that the PVC Braided Hose can reach. The electrolyzed water may not be able to flow or the flow rate may not be maintained if the total piping length is outside this range. Adjust the pipe length using the PVC Braided Hose to maintain the proper performance of the electrolyzed water. Install the Remote Controller so that the outlets are located above the unit. The difference in the gas amount between acid (sanitizing) water and alkaline (cleaning) water may change the flow rate balance and cause poor performance.

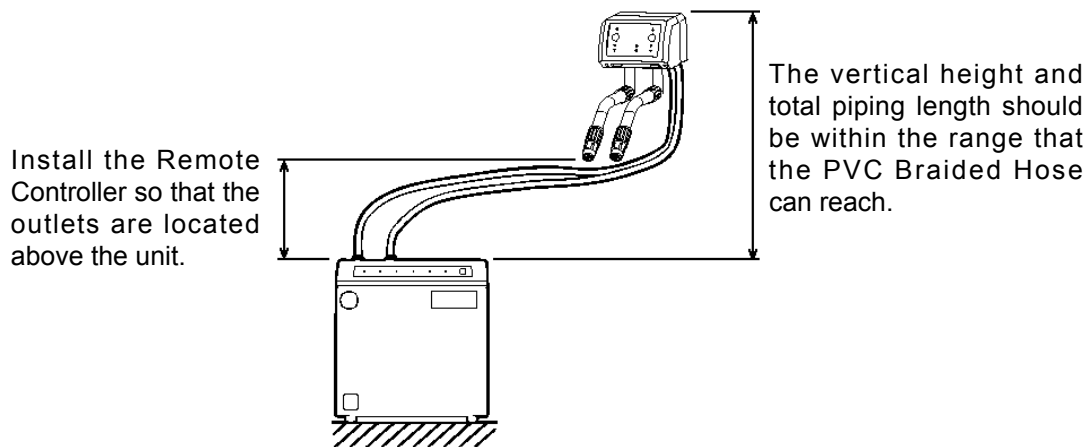

6) Attach the caution label (Accessory) in readily visible position near the Remote Controller.

## [d] ELECTRICAL CONNECTION

\* Usually an electrical permit and services of a licensed electrician are required.

1) Remove the three screws securing the Side Panel.

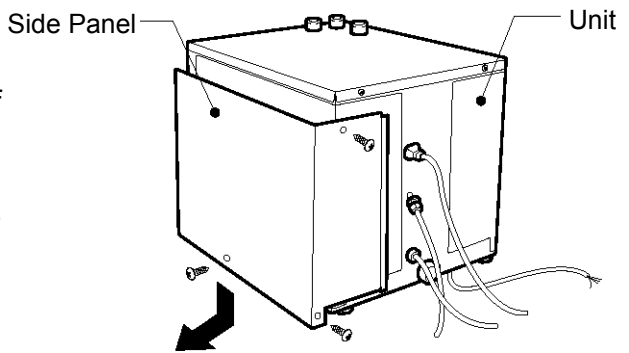

2) Connect the cable connector on the Remote Controller with the connector on the Control Box.

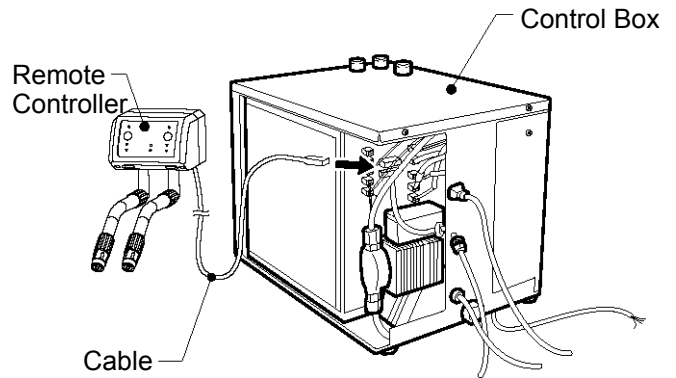

3) Attach the bushing on the cable to the Rear Panel.

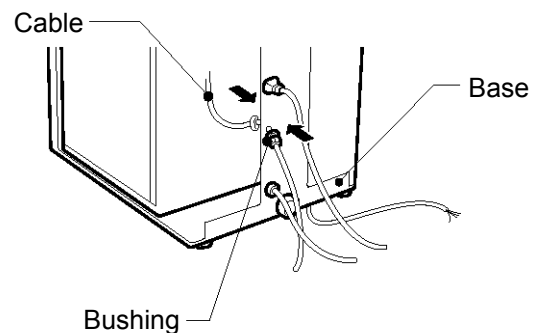

4) Replace the Side Panel in the original position with screws.

## 6. INSTALLATION OF WATER TANK FLOAT SWITCHES (OPTION) AND WATER TANK (SOLD SEPARATELY)

Please note that the instructions and illustrations below are based on ROX-20TB-E and that only one water outlet is available for JIX-40T\_.

### [a] CHECKS BEFORE INSTALLATION

- 1) Unpack and remove shipping carton, tape(s) and other packaging material(s).
- 2) Check that all the necessary accessories are included.
- 3) Check that the water electrolyzer and Water Tank are installed so that the cables of the Float Switches can reach from the water electrolyzer to the Water Tank.
- 4) A stand may be needed to support the Water Tank depending on the application. Check if the floor can support the weight of the Water Tank when it is full.
- 5) The Water Tank should have a cover with a small ventilation opening to the atmosphere. The Water Tank should not be exposed to direct sunlight.

## [b] LOCATION

### WARNING

1. These float switches and water tank are not intended for outdoor use. Normal operating ambient temperature should be within +40°F to 95°F (+5°C to +35°C); Normal operating water temperature should be within +40°F to 85°F (+5°C to +30°C). Operation of the float switches and water tank for extended periods outside of these normal temperature ranges may affect performance.
2. Do not install the float switches and water tank where exposed to humidity or splashing water. Reduction in insulation property may cause an electric leak or shock.
3. Install an adequate ventilating system. Hydrogen gas or chlorine gas may cause health problems.

### CAUTION

1. Avoid a site where dripping is not allowed. Condensation may form on the exterior in high humidity and could drip onto the floor.
2. Use glass, plastic or stainless steel containers for electrolyzed water. Acid (sanitizing) water may corrode metal.

For best operating results:

- \* The Water Tank should not be located next to ovens, grills or other high heat producing equipment.
- \* Location should provide a firm and level foundation for the equipment.
- \* Allow min. 60 cm (24") clearance at rear, sides and top for ease of maintenance and/or service.
- \* Install the unit in a well-ventilated area. Use fans with diameter over 15 cm (6 inches) [standard air flow rate: 450 m<sup>3</sup>/h (270 ft<sup>3</sup>/min)] if necessary.

## [c] SET UP

### CAUTION

Use the PVC Pipes, Connectors and Gaskets or PVC pipes for electrolyzed water piping. Other materials may cause corrosion and water leakage.

- 1) Drill two attachment holes each in the Acid Water Tank and Alkaline (Cleaning) Water Tank to attach the Float Switches.

Note: The diameter of the attachment hole for the Float Switches is 14 mm (9/16"). The minimum vertical distance between two attachment holes is 70 - 80 mm (2.8 - 3.2").

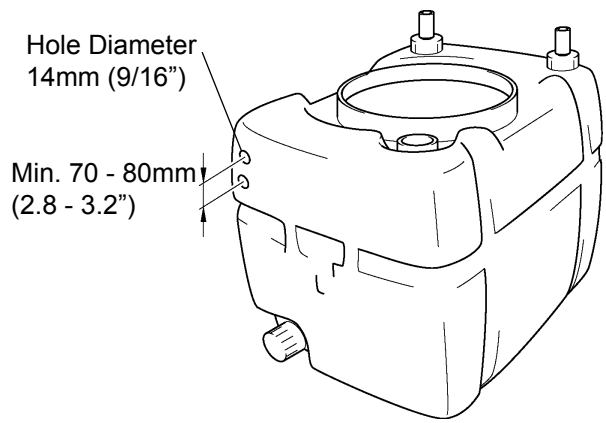

- 2) Cut the fitting nut from each Float Switch.

- 3) Follow the Label on each Float Switch. Place the Float Switch in each tank and pull the cable through the 2 holes out of the tank. Then reconnect the fitting nut to the cable and secure the Float Switch to the tank.

Note: Be sure to check the direction of the Float Switch.

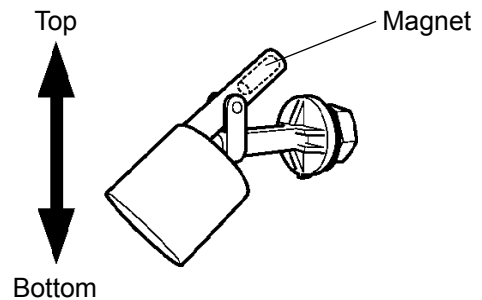

- 4) Secure each water tank with a belt, framing or other securing device so that it will not tip or fall.

#### [d] ELECTRICAL CONNECTION

- \* Usually an electrical permit and services of a licensed electrician are required.
- \* To operate the unit in the Pool Mode, replace the XM Connector (5P) [red] with the accessory XM Connector (5P) [blue]. See "9. [a] OPERATION MODE".

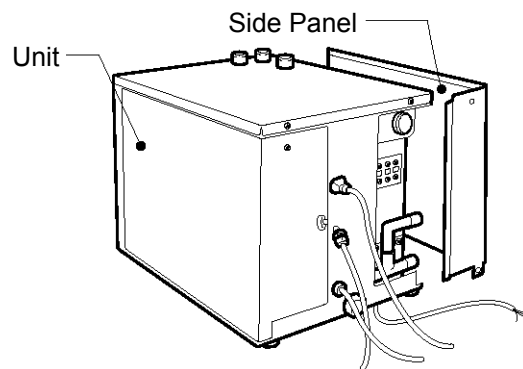

- 1) Remove the three screws securing the Side Panel.
- 2) Remove the plastic cover of the Terminal Block located under the Gear Motor inside the unit.
- 3) Connect the Connectors attached to the Float Switches so that the colors of the Connectors match.

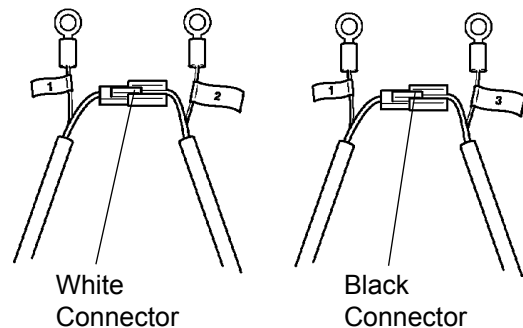

4) Connect round eyelet contacts to the Terminal Block matching the numbers according to the label on the wires.

5) Replace the plastic cover of the Terminal Block in the original position.

Terminal Block

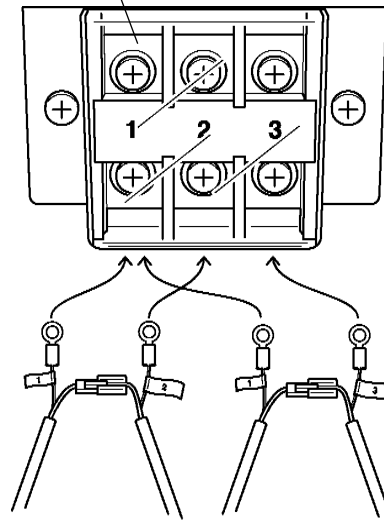

6) Remove two blind bushings from the unit base and attach the cables to the unit base using the bushings attached to the Float Switch.

Note: Use one bushing for 2 cables.

7) Replace the Side Panel in the original position with screws.

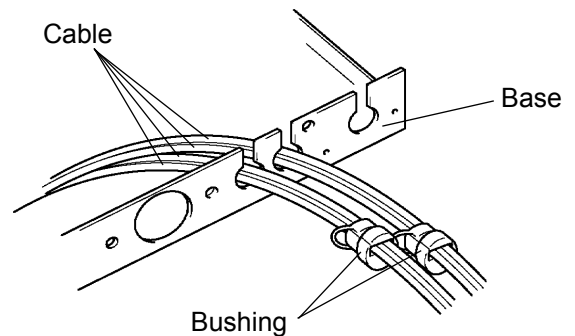

## 7. INSTALLATION OF OUTLET VALVES (OPTION)

Please note that the instructions and illustrations below are based on ROX-20TB-E and that only one water outlet is available for JIX-40T\_.

### [a] CHECKS BEFORE INSTALLATION

- 1) Unpack and remove shipping carton, tape(s) and other packaging material(s).
- 2) Check that all the necessary accessories are included.

### [b] LOCATION

#### WARNING

1. This outlet valve is not intended for outdoor use. Normal operating ambient temperature should be within 5°C to 35°C (40°F to 95°F); Normal operating water temperature should be within 5°C to 30°C (40°F to 85°F). Operation of the outlet valve for extended periods outside of these normal temperature ranges may affect performance.
2. Install an adequate ventilating system. Hydrogen gas or chlorine gas may cause health problems.

## CAUTION

1. Avoid a site where dripping is not allowed. Condensation may form on the exterior in high humidity and could drip onto the floor.
2. Use glass, plastic or stainless steel containers for electrolyzed water. Acid (sanitizing) water may corrode metal.

For best operating results:

- \* The Outlet Valves should not be located next to ovens, grills or other high heat producing equipment.
- \* Location should provide a firm and level foundation for the equipment.
- \* Install the unit in a well-ventilated area. Use fans with diameter over 15 cm (6 inches) [standard air flow rate: 450 m<sup>3</sup>/h (270 ft<sup>3</sup>/min)] if necessary.

### [c] SET UP

## CAUTION

Use the PVC pipes for electrolyzed water piping. Other materials may cause corrosion and water leakage.

- 1) Choose a dispense method (Water Pump or Water Tank) depending on the installation situation. Install PVC pipes from the Water Tank to the location where electrolyzed water is used.

Note: In case of using a Water Pump, follow the instruction manual for electric wiring and piping.

- 2) Connect the Valve with the Flexible Pipe.

Note: Before fitting the Flexible Pipes into the Valves, wrap the pipe threads with sealing tapes.

Do not misconnect the Accessory Flexible Pipes:

Yellow pipe - Acid (sanitizing) water

Blue pipe - Alkaline (cleaning) water

The Valves are common to both acid (sanitizing) and alkaline (cleaning) water.

- 3) Install the Outlet Valves on the wall using the M4 x 8 Screws (Accessory), etc. depending on the installation condition. Install the Outlet Valves on pipes from each Water Tank. Outlet Valve Inlet is 1/2 Female Pipe Thread (FPT).

Note: When mounting the Valves on a wall surface, locate:  
Acid (sanitizing) water valve (yellow pipe) on your right  
Alkaline (cleaning) water valve (blue pipe) on your left

- 4) Attach the labels (acid water, alkaline water, and caution) in readily visible positions near the valves.

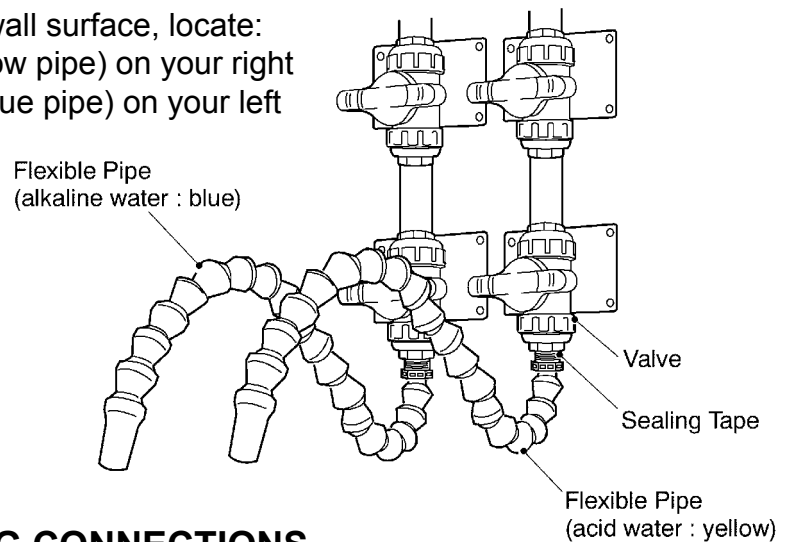

## 8. WATER SUPPLY AND PLUMBING CONNECTIONS

Please note that the instructions and illustrations below are based on ROX-20TB-E and that only one water outlet is available for JIX-40T\_.

### [a] UNIT WITH REMOTE CONTROLLER, WATER SOFTENER & WATER FILTER

#### CAUTION

1. Do not run the water electrolyzer until adequate water pressure [0.15 - 0.78 MPa (22 - 115 PSIG)] is reached.
2. The vertical height of the pipe and total length of the pipes for acid (sanitizing) and alkaline (cleaning) water should be the same. Different pipe lengths may cause an unstable amount of acid (sanitizing) and alkaline (cleaning) water to be generated, poor performance or damage to the unit.
3. Keep the end of the electrolyzed water pipes open. Do not install a shut-off valve on the end of the pipe, connect a hose with the end of the water outlet or immerse the end of the pipe in water. Different pipe lengths may cause an unstable amount of acid (sanitizing) and alkaline (cleaning) water to be generated, poor performance or damage to the unit.
4. Pour electrolyzed water down a drain after it is neutralized. Putting electrolyzed water down a drain without neutralizing it may cause rusty pipes and water leakage.
5. Do not install the unit where there is a possibility of freezing. Remove water from the unit if ambient temperature may fall below 0°C (32°F). Frozen water may damage water supply pipes and cause water leakage.
6. Maintain water supply pressure to the unit within 0.15 - 0.78 MPa (22 - 115 PSIG). Excessively low or high water pressure may cause poor performance of acid (sanitizing) and alkaline (cleaning) water, trouble or water leakage from the connections.

\* Be sure to install the Pressure Reducing Valve after the Water Filter and Water Pressure Gauge. Pressure Reducing Valve Inlet is 1/2" male pipe thread (MPT). The water electrolyzer will not work properly without the Pressure Reducing Valve.

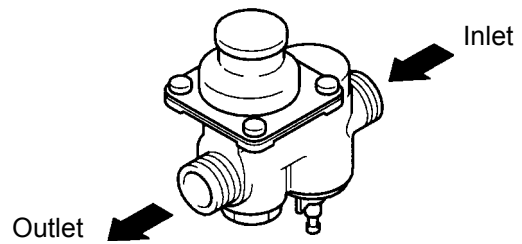

Note: Be sure to check the direction of the Pressure Reducing Valve.

\* Water supply inlet is 3/4" MPT. Connect the unit with the Pressure Reducing Valve using the Water Supply Hose (Accessory).

Note: Place the Gaskets between the Water Supply Hose and unit water supply inlet and the Pressure Reducing Valve and tighten properly. Incomplete connection may cause water leakage.

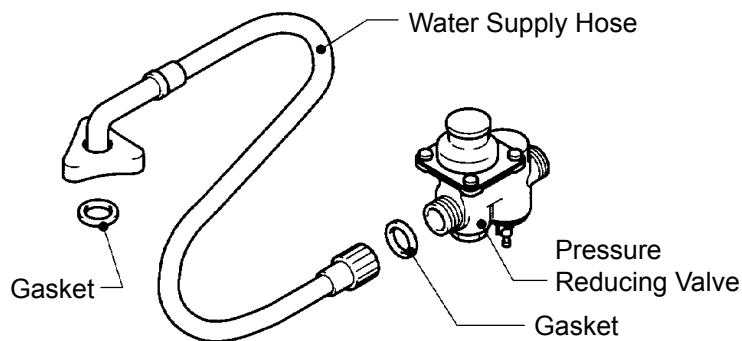

\* Prepare a drain hose with a plastic shut-off valve if water needs to be removed from the unit or water may freeze in the unit in cold areas. Remove the drain cap on the back of the unit and attach the plastic joint, vinyl or PVC hose and plastic shut-off valve. Drain outlet is 1/2" female pipe thread (FPT).

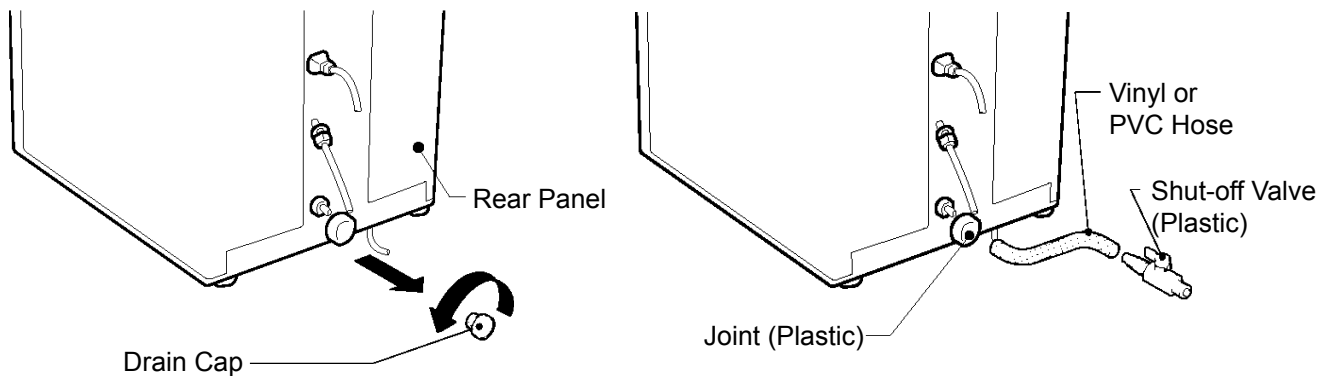

\* Put the Salt Water Hose through the Cap (Accessory) and push in the Salt Water Hose until the Stopper hits the Cap.

Note: Install the Remote Controller so that the outlets are located above the Salt Water Filter on the end of the Salt Water Hose. Due to the siphon phenomenon, salt water may leak from the outlets of the Remote Controller if the Remote Controller outlets are not high enough.

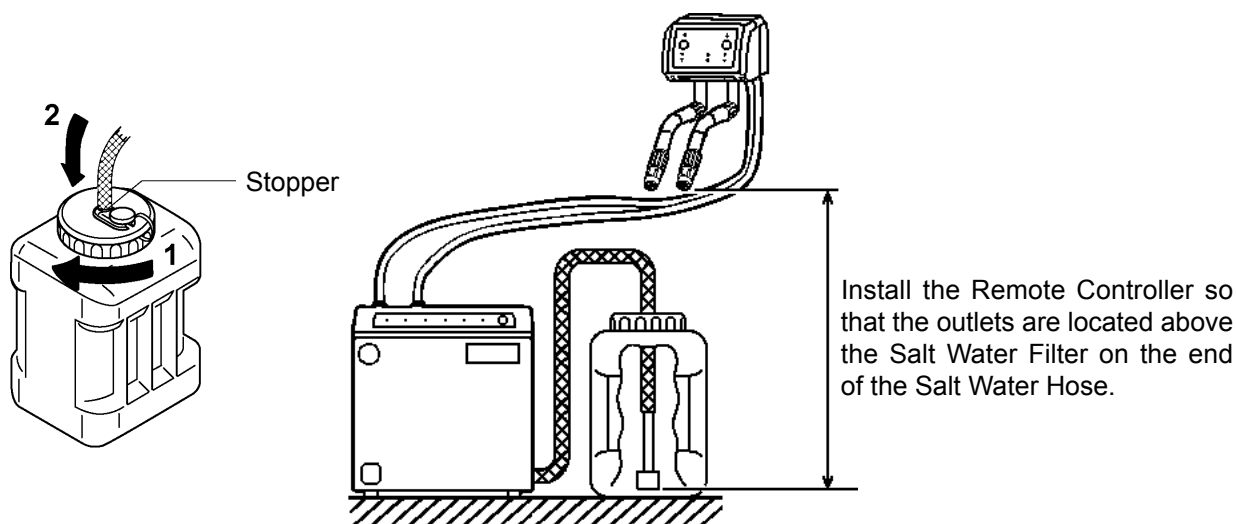

- \* A water supply line shut-off valve and drain valve should be installed.
- \* The drains should not be piped directly to the sewer system. An air gap of a minimum of 5 vertical cm (2 vertical inches) should be between drain pipe ends and the floor drain, the hose ends from the water electrolyzer and the floor drain, and the water supply line drain valve and the floor drain.
- \* This water electrolyzer should be installed in accordance with applicable national, state and local regulations.
- \* A plumbing permit and services of a licensed plumber may be required in some areas.

\* Piping Example

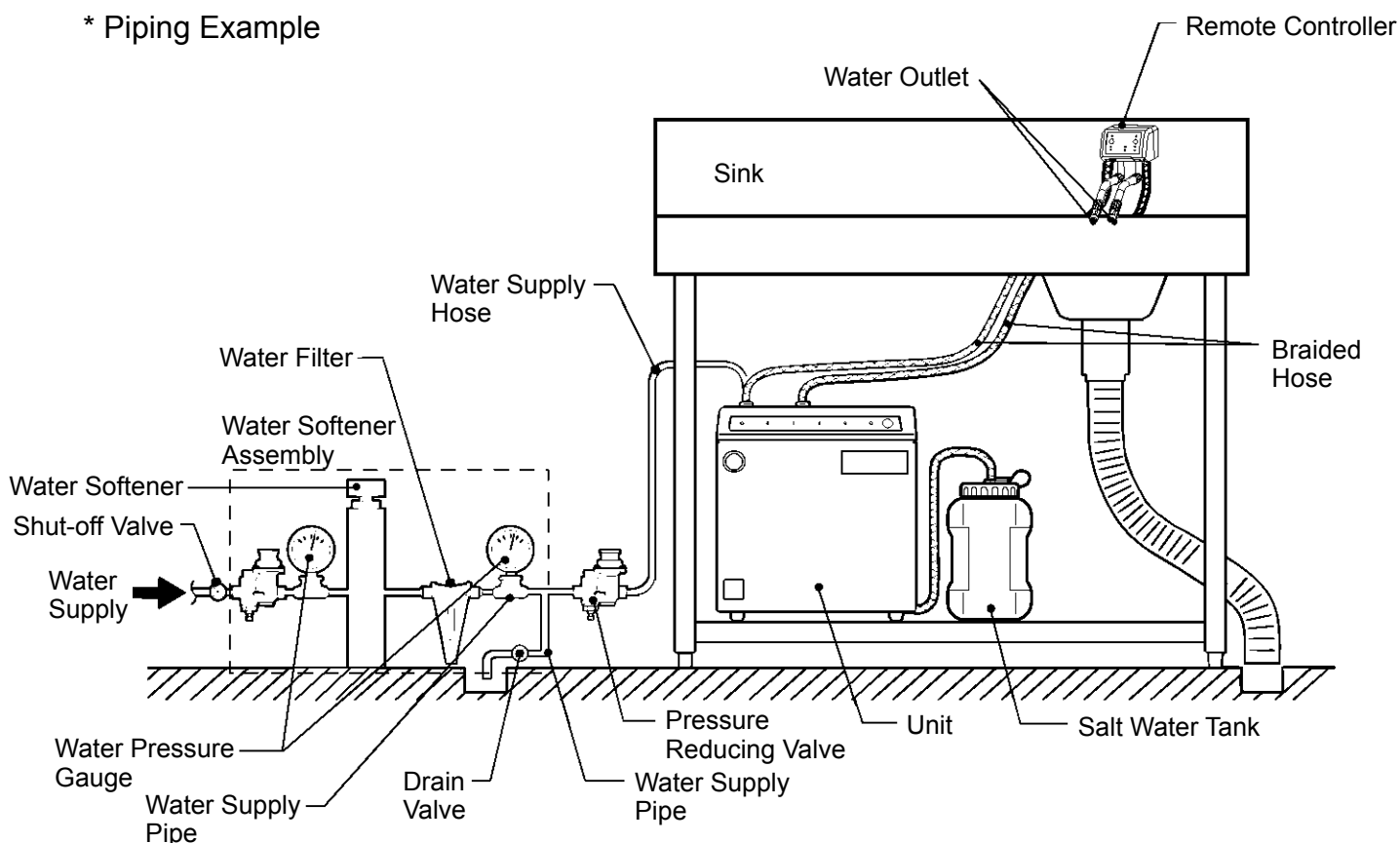

## [b] UNIT WITH WATER TANK, WATER SOFTENER & WATER FILTER

### CAUTION

1. Do not run the water electrolyzer until adequate water pressure [0.15 - 0.78 MPa (22 - 115 PSIG)] is reached.
2. The vertical height of the pipe and total length of the pipes for acid (sanitizing) and alkaline (cleaning) water should be the same. Different pipe lengths may cause an unstable amount of acid (sanitizing) and alkaline (cleaning) water to be generated, poor performance or damage to the unit.
3. Keep the end of the electrolyzed water pipes open. Do not install a shut-off valve on the end of the pipe, connect a hose with the end of the water outlet or immerse the end of the pipe in water. Different pipe lengths may cause an unstable amount of acid (sanitizing) and alkaline (cleaning) water to be generated, poor performance or damage to the unit.
4. Pour electrolyzed water down a drain after it is neutralized. Putting electrolyzed water down a drain without neutralizing it may cause rusty pipes and water leakage.
5. Do not install the unit where there is a possibility of freezing. Remove water from the unit if ambient temperature may fall below 0°C (32°F). Frozen water may damage water supply pipes and cause water leakage.
6. Maintain water supply pressure to the unit within 0.15 - 0.78 MPa (22 - 115 PSIG). Excessively low or high water pressure may cause poor performance of acid (sanitizing) and alkaline (cleaning) water, trouble or water leakage from the connections.
7. Use the Accessory Braided Hoses, Connectors and Gaskets or PVC pipes for electrolyzed water piping. Other materials may cause corrosion and water leakage.
8. Use sealing agents, sealing tape or gaskets to prevent water leakage when connecting pipes.

\* Be sure to install the Pressure Reducing Valve after the Water Filter and Water Pressure Gauge. Pressure Reducing Valve Inlet is 1/2" male pipe thread (MPT). The water electrolyzer will not work properly without the Pressure Reducing Valve.

Note: Be sure to check the direction of the Pressure Reducing Valve.

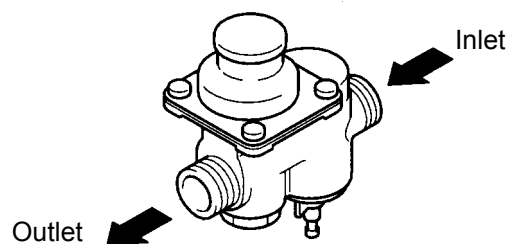

\* Water supply inlet is 3/4" MPT. Connect the unit with the Pressure Reducing Valve using the Water Supply Hose (Accessory).

Note: Place the Gaskets between the Water Supply Hose and unit water supply inlet and the Pressure Reducing Valve and tighten properly. Incomplete connection may cause water leakage.

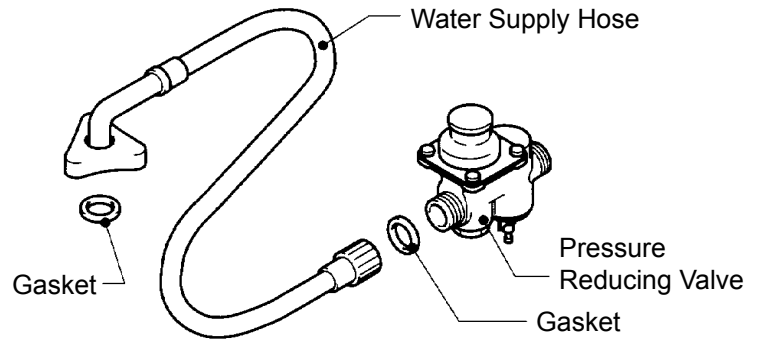

\* Prepare a drain hose with a plastic shut-off valve if water needs to be removed from the unit or water may freeze in the unit in cold areas. Remove the drain cap on the back of the unit and attach the plastic joint, vinyl or PVC hose and plastic shut-off valve. Drain outlet is 3/4" female pipe thread (FPT).

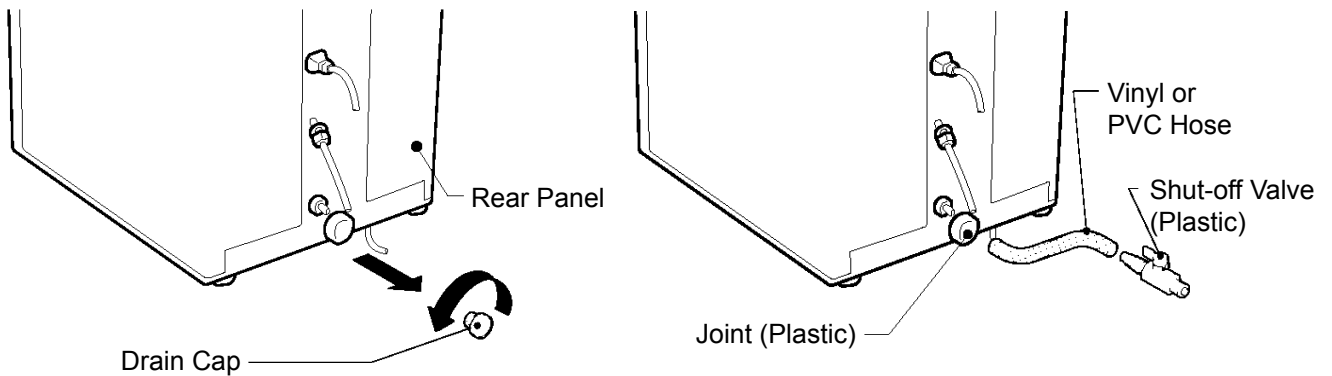

\* Put the Salt Water Hose through the Cap (Accessory) and push in the Salt Water Hose until the Stopper hits the Cap. In case of using a larger tank, install the Salt Water Hose so that the filter on the Salt Water Hose can reach the bottom of the tank.

Note: Install the piping so that the outlets are located above the Salt Water Filter on the end of the Salt Water Hose. Due to the siphon phenomenon, salt water may leak from the outlets if they are not high enough.

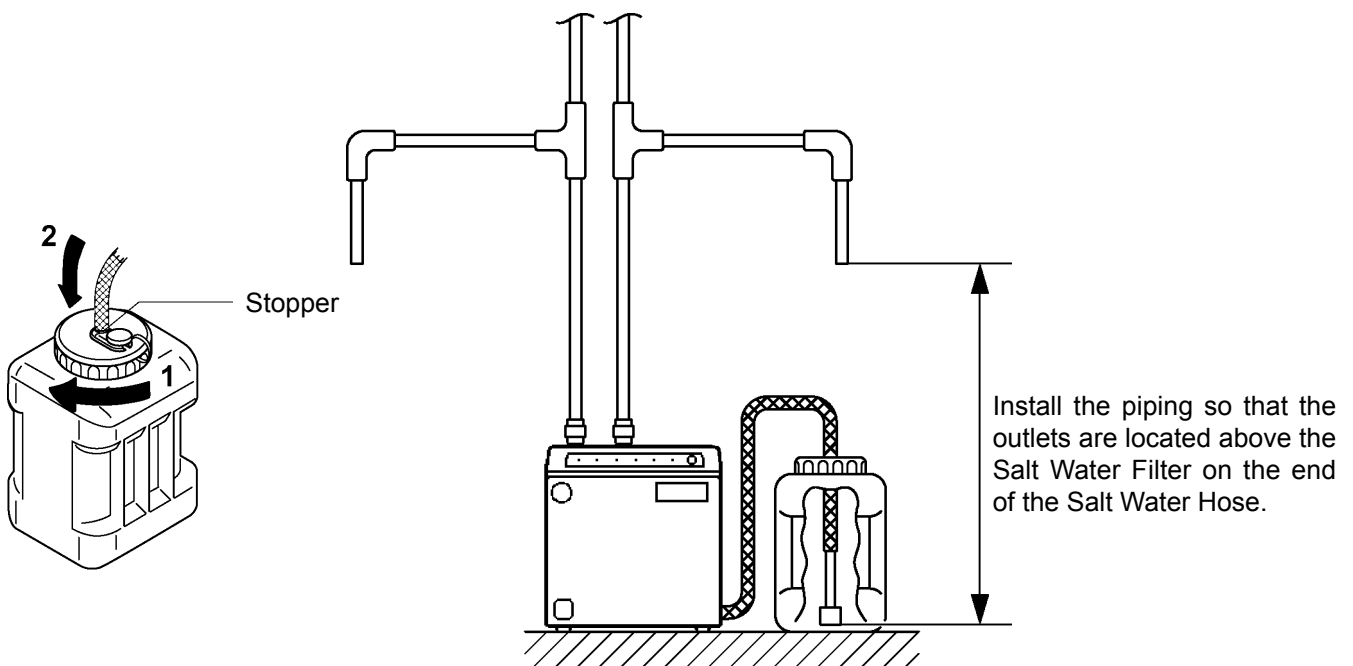

\* Acid (Sanitizing) and Alkaline (Cleaning) Water Discharge Outlet is 1/2" MPT.

Note: The vertical length of the pipes for electrolyzed water should be a maximum of 2 m (80"). The electrolyzed water may not be able to flow or the flow rate may not be maintained if the piping length is outside of this range. Install the piping to the Water Tank so that the outlets are located above the unit. The difference in the gas amount between acid (sanitizing) water and alkaline (cleaning) water may change the flow rate balance and cause poor performance. Use unions between the pipes and the unit so that the hoses can be removed from the unit easily.

\* Be sure to install vent pipes on the piping for electrolyzed water.

Note: Use 1/2-3/4" pipes for vertical piping and 3/4" for horizontal piping and vent piping. This can reduce the influence of scale in the alkaline (cleaning) water pipe and help stabilize the amount of alkaline (cleaning) water to generate. Also be sure to have about 5/100 pitch (downward) for horizontal piping.

\* Be sure to install PVC or acid and alkaline resistant inspection valves on the vertical piping to measure acid (sanitizing) and alkaline (cleaning) water.

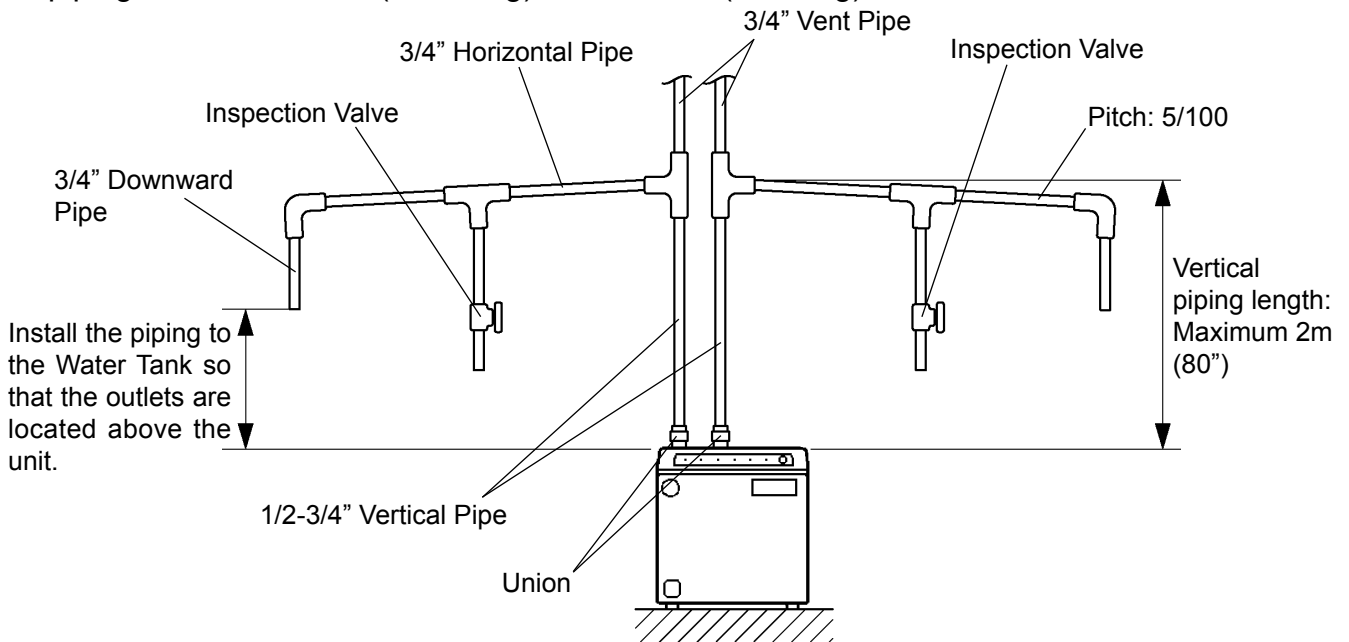

\* Be sure to install overflow pipes and drain pipes on the Water Tanks.

Note: Use 3/4" overflow and drain pipes. Install traps on the overflow pipes and either PVC or acid and alkaline resistant shut-off valves on the drain pipes. Locate the overflow pipes so that they will be located above the Float Switches on each Water Tank.

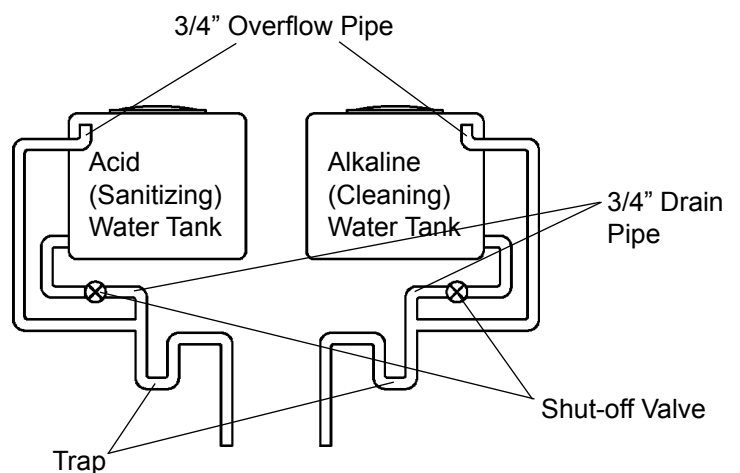

- \* A water supply line shut-off valve and drain valve should be installed.
- \* The drains must have 1/4" fall per foot on horizontal runs to get a good flow.
- \* The drains should not be piped directly to the sewer system. An air gap of a minimum of 5 vertical cm (2 vertical inches) should be between drain pipe ends and the floor drain, the hose ends from the water electrolyzer and the floor drain, and the water supply line drain valve and the floor drain.
- \* This water electrolyzer should be installed in accordance with applicable national, state and local regulations.
- \* A plumbing permit and services of a licensed plumber may be required in some areas.
- \* Piping Example

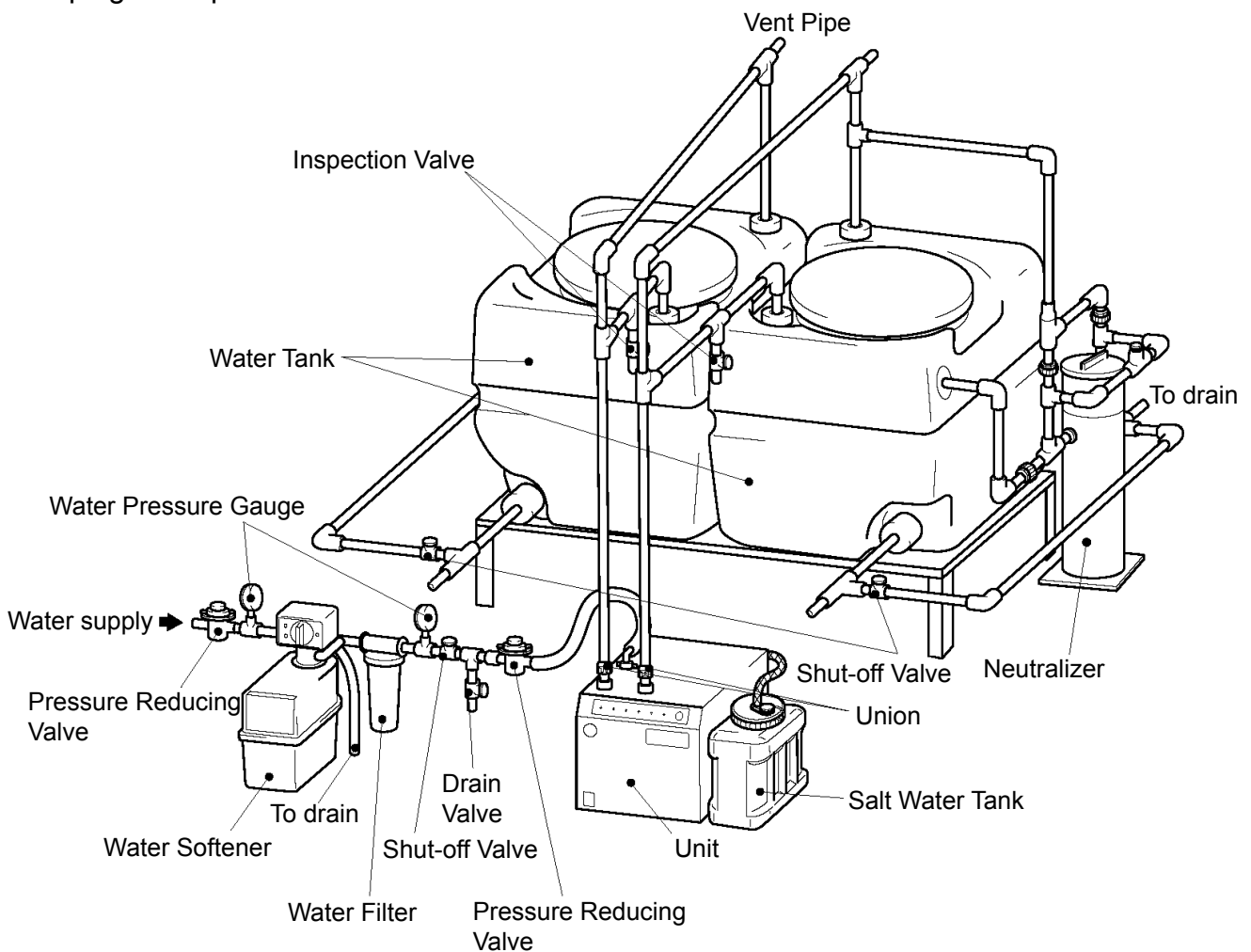

## 9. ADJUSTMENT

### [a] OPERATION MODE

#### CAUTION

Be sure to set the operation mode before operating the unit with the Remote Controller or the Water Tank. Operating the unit without setting the operation mode may lower the performance of the electrolyzed water or spilling of acid (sanitizing) electrolyzed water and/or alkaline (cleaning) electrolyzed water.

The operation mode can be selected from the following two options:

Hand Mode (Connector wire color: Red)

Electrolysis is started by turning on the Power Switch and then the Dispense Button.

Pool Mode (Connector wire color: Blue)

Electrolysis is started by turning on the Power Switch.

The operation mode is factory adjusted to the Hand Mode and can be changed to the Pool Mode by replacing the Model Setting Connector on the Control Box with the accessory XM Connector (5P).

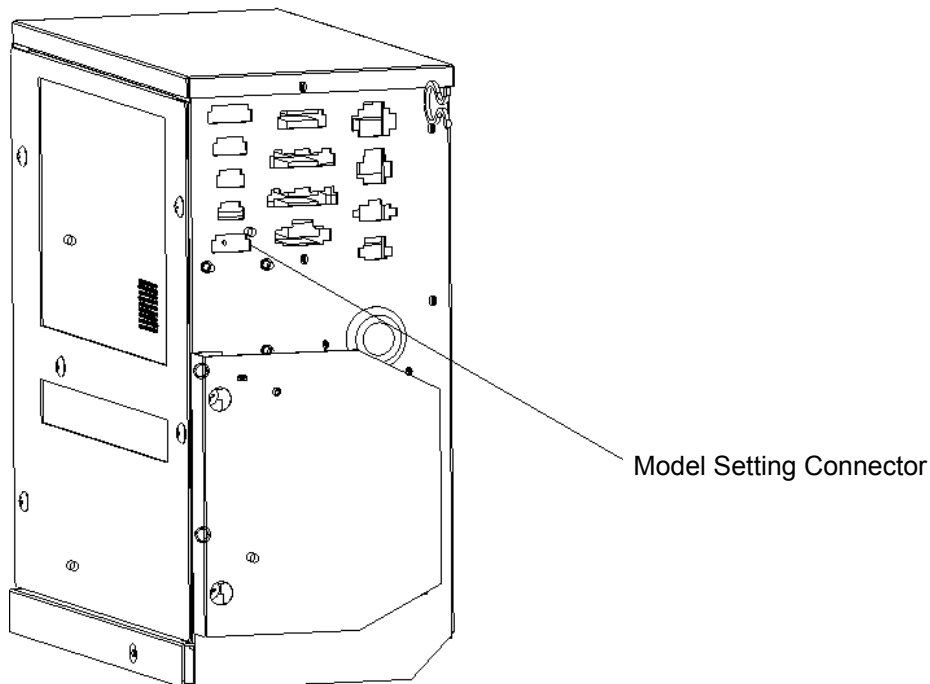

**[b] CURRENT, VOLTAGE, PORTION CONTROL DISPENSING TIME, HANDWASHING TIME (ROX-20TB-E)**

**IMPORTANT**

Contact an authorized Hoshizaki service company before adjusting the current or voltage. Improper adjustment may cause an excessive chlorine concentration in acid (sanitizing) water, resulting in health problems, corrosion, or deviation from the food additive or disinfectant requirements.

- 1) Turn on the Power Switch.
- 2) For current or voltage adjustment only, press the Flow Rate Button to illuminate the selected Flow Rate Lamp (LO, MID or HI).
- 3) Hold down the Set Button.
- 4) Check that the Display Window is showing "Nor". "Nor" indicates that the unit is currently in the Normal Mode.
- 5) Press the Display Select Button once while holding down the Set Button.
- 6) Check that the Display Window is showing "AdJ". "AdJ" indicates that the unit is currently in the Adjust Mode.
- 7) Release the Set Button.
- 8) Check that the Display Window is showing "A1". "A1" indicates that the unit is in Stage 1 of the Adjust Mode. Press the Display Select Button to select the appropriate stage.
  - A1: Current
  - A2: Voltage
  - A5: Portion control dispensing time
  - A6: Handwashing time [alkaline (cleaning) water]
  - A7: Handwashing time [acid (sanitizing) water]
- 9) If the Display Select Button is pushed more than necessary and the Display Window shows a code other than desired, continue to push the Display Select Button until the proper code reappears.
- 10) Press the Flush Button once.
- 11) The Display Window will flash the current setting. The factory settings are as follows:
  - Current: "10.0" (10A)
  - Voltage: "12.0" (12V)
  - Portion control dispensing time: "1" (1 minute)
  - Handwashing time: "30" (30 seconds)

- 12) Press the Display Select Button (Up) or Flush Button (Down) until the desired value is displayed. The Display Window continues to flash.  
To raise the available chlorine concentration, increase the current or decrease the voltage. To lower the concentration, decrease the current or increase the voltage.
- 13) When the desired value appears in the Display Window, press the Set Button once.
- 14) The value displayed in the Display Window will stop flashing. Check that the Adjust Mode Code appears in the Display Window.
- 15) Press the Display Select Button once holding down the Set Button.
- 16) Check that "CHE" is displayed in the Display Window. "CHE" indicates that the unit is in the Check Mode.
- 17) Press the Display Select Button one more time holding down the Set Button.
- 18) Check that "Nor" is displayed in the Display Window.
- 19) Release the Set Button.
- 20) This is the end of setting. Check for proper operation.

**[c] CURRENT, VOLTAGE, PORTION CONTROL DISPENSING TIME (JIX-40T\_)**

**IMPORTANT**

Contact an authorized Hoshizaki service company before adjusting the current or voltage. Improper adjustment may cause an excessive chlorine concentration, resulting in health problems, corrosion, or deviation from the food additive or disinfectant requirements.

- 1) Turn on the Power Switch.
- 2) Hold down the Set Button.
- 3) Check that the Display Window is showing "Nor". "Nor" indicates that the unit is currently in the Normal Mode.
- 4) Press the Display Select Button once while holding down the Set Button.
- 5) Check that the Display Window is showing "AdJ". "AdJ" indicates that the unit is currently in the Adjust Mode.
- 6) Release the Set Button.

- 7) Check that the Display Window is showing "A1". "A1" indicates that the unit is in Stage 1 of the Adjust Mode. Press the Display Select Button to select the appropriate stage.
  - A1: Current
  - A2: Voltage
  - A5: Portion control dispensing time
- 8) If the Display Select Button is pushed more than necessary and the Display Window shows a code other than desired, continue to push the Display Select Button until the proper code reappears.
- 9) Press the Flush Button once.
- 10) The Display Window will flash the current setting. The factory settings are as follows:
  - Current: "10.0" (10A)
  - Voltage: "12.0" (12V)
  - Portion control dispensing time: "1" (1 minute)
- 11) Press the Display Select Button (Up) or Flush Button (Down) until the desired value is displayed. The Display Window continues to flash.  
To raise the available chlorine concentration, increase the current or decrease the voltage. To lower the concentration, decrease the current or increase the voltage.
- 12) When the desired value appears in the Display Window, press the Set Button once.
- 13) The value displayed in the Display Window will stop flashing. Check that the Adjust Mode Code appears in the Display Window.
- 14) Press the Display Select Button once holding down the Set Button.
- 15) Check that "CHE" is displayed in the Display Window. "CHE" indicates that the unit is in the Check Mode.
- 16) Press the Display Select Button one more time holding down the Set Button.
- 17) Check that "Nor" is displayed in the Display Window.
- 18) Release the Set Button.
- 19) This is the end of setting. Check for proper operation.

**[d] FLOW RATE (JIX-40T\_)**

**IMPORTANT**

Contact an authorized Hoshizaki service company before adjusting the flow rate.

- 1) Open the Door, and remove the Cover in front of the Electrolytic Cell.

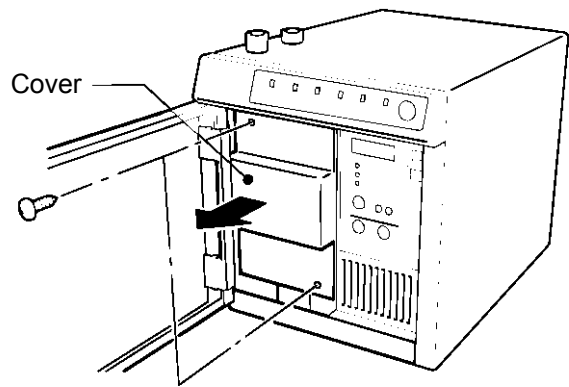

- 2) The Flow Rate Valve is located on the left side. Turn the Flow Rate Valve clockwise to decrease and counterclockwise to increase the flow rate.

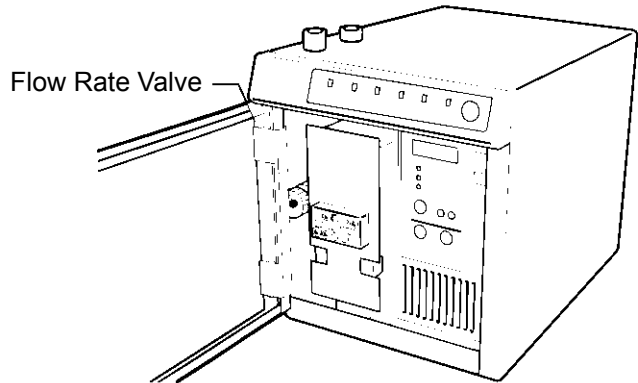

- 3) After completing the adjustment, replace the Cover in its correct position.

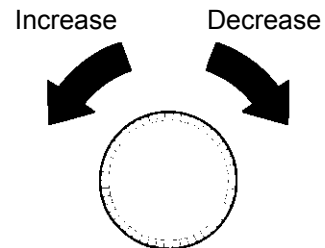

## 10. FINAL CHECK LIST

- 1) Is the water electrolyzer level?
- 2) Is the water tank level?
- 3) Is the water electrolyzer in a site where the ambient temperature is within 5°C to 35°C (40°F to 95°F) and the water temperature within 5°C to 30°C (40°F to 85°F) all year around?
- 4) Is there at least 15 cm (6") clearance at rear, sides and top of the water electrolyzer for maintenance or service?
- 5) Is there at least 60 cm (24") clearance at rear, sides and top of the water tank for maintenance or service?
- 6) Have all electrical and piping connections been made?
- 7) Have the water softener and water filter been installed?
- 8) Is water from the water softener soft?
- 9) Are you using potable water?

- 10) Has the power supply voltage been checked or tested against the nameplate rating?
- 11) Have the water supply line shut-off valve and drain valve been installed? Has the water supply pressure been checked to ensure a minimum of 0.15 MPa (22 PSIG) and a maximum of 0.78 MPa (115 PSIG)?
- 12) Is the water tank securely fixed?
- 13) Has the pressure reducing valve been installed?
- 14) Is the installation area well ventilated?
- 15) Has the operation mode been set?
- 16) Has the end user been given the instruction manual, and instructed on how to operate the water electrolyzer and the importance of the recommended periodic maintenance?
- 17) Has the end user been given the name and telephone number of an authorized service agent?
- 18) Has the warranty tag been filled out and forwarded to the factory for warranty registration?

## 11. WATER TANK FLOAT SWITCHES (OPTION)

Includes the Upper and Lower Acid (Sanitizing) Water Tank Level Float Switches and Upper and Lower Alkaline (Cleaning) Water Tank Level Float Switches.

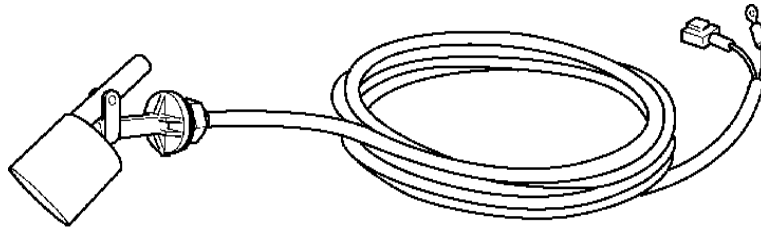

## 12. OUTLET VALVES (OPTION)

Connected with the Electrolyzed Water Outlets [for acid (sanitizing) and alkaline (cleaning) water outlets] on the Water Tank. Use as needed [yellow for acid (sanitizing) water, blue for alkaline (cleaning) water].

